

YSP40 SERIES**Input:100-240VAC 50/60Hz****Output Voltage: 12-55V DC****Rated Power :36W max****Features**

High Efficiency
Standby Power < 0.1W
Energy Efficiency Level VI
Standard: IEEE802.3af/at
Data rate:10/100/1000Mbps
Protections: Short Circuit, OCP,OVP
Three-year Warranty

Application

IP Phones,Wireless Networks Access Points,
IP print servers, Blue tooth access points,
IP Cameras, UPS, Switch, Smart door system etc.

CE RoHS

■ Dimensions and Installation

Dimensions: (mm)

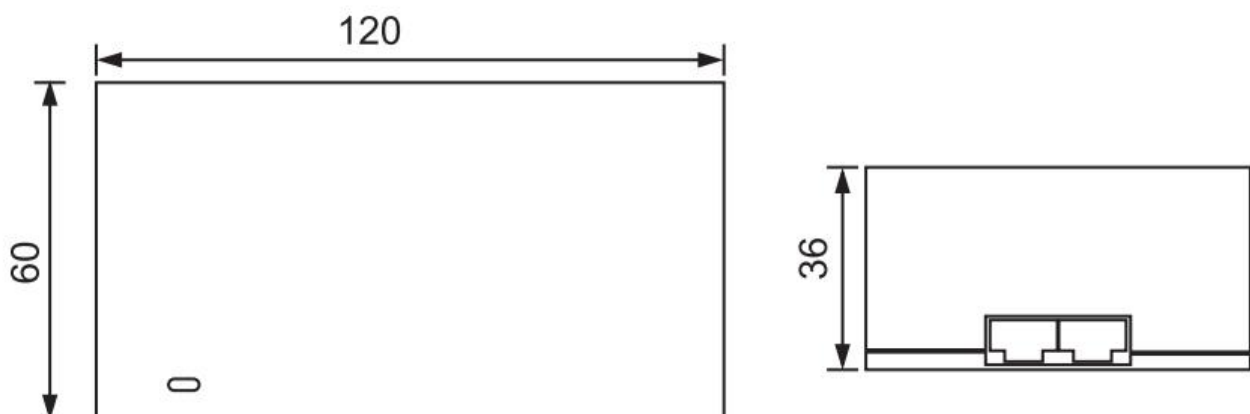

YSP40 SERIES

MODEL DETAIL SPEC.		YSP40-1203000	YSP40-2401500	YSP40-3601000	YSP40-4800750	YSP40-5500650
INPUT	Input Voltage:	100-240VAC				
	Input Frequency:	50/60Hz				
	Inrush Current:	50 Amps max. at 230VAC/50Hz, full load				
	AC Current:	0.8A max.				
	Leakage Current:	0.25mA Max. at 264VAC input				
	Efficiency:	87.4%	87.4%	87.4%	87.4%	87.4%
OUTPUT	DC Voltage:	12V	24V	36V	48V	55V
	Rated Current:	0-3A	0-1.5A	0-1A	0-0.75A	0-0.65A
	Rated Power:	36W	36W	36W	36W	36W
	Voltage Tolerance:	±5.0%	±5.0%	±5.0%	±5.0%	±5.0%
	Ripple and Noise:	120mVp-p	240mVp-p	360mVp-p	480mVp-p	550mVp-p
	Line Regulation:	±3%	±3%	±3%	±3%	±3%
	Load Regulation:	±5.0%	±5.0%	±5.0%	±5.0%	±5.0%
	Setup, Rise, Hold Up time:	2S/ 80mS/ 15mS (115V/60HZ MAX ROAD) 1S/ 80mS/ 30mS (230V/50HZ MAX ROAD)				
ENVIRONMENTAL	Operating Temperature:	-20 ~ +60 (Refer to "Derating Curve")				
	Storage Temp:	-40°C ~ 85°C				
	Storage Humidity:	-40°C ~+70°C ambient temperature a 5% to 95% relative humidity range throughout an altitude range of -60 meters to +5000 meters AMSL.				
	Working Humidity:	-40°C ~+70°C ambient temperature a 5% to 95% relative humidity range throughout an altitude range of -60 meters to +5000 meters AMSL.				
PROTECTION	Over Load	Above 105% rated output power				
		Protection type: Hiccup mode, recovers automatically after fault condition is removed.				
	Over Voltage:	≤Vout* 150%				
	Short Circuit:	Protection to Zero Voltage				
SAFETY & EMC	Safety Regulations:	IEEE802.3at/af (POE)				
	Withstand Voltage:	I/P-O/P:3KVAC I/P-FG:2KVAC O/P-FG:0.5KVAC				
	Isolation Resistance:	I/P-O/P: 100M Ohms / 500VDC / 25 / 70% RH				
	EMC Emission:	Radiation Test&Conduction Test: EN 55022/FCC Part 15 Harmonic Test : EN 61000-3-2 Flicker Test : EN 61000-3-3				
	EMC Immunity:	ESD Test:EN 61000-4-2 RS Test:EN 61000-4-3 EFT Test:EN 61000-4-4 Surge Test:EN 61000-4-5 CS Test:EN 61000-4-6				
	MTBF:	100,000 Hours Minimum at Full Load at 25°C Ambient				

YSP40 SERIES

Deduction curve and temperature

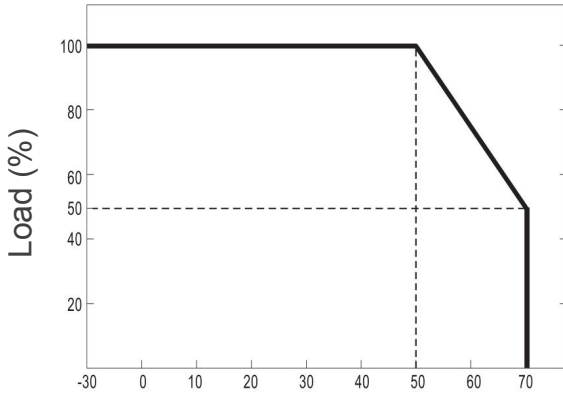

Environment temperature(°C)

Minus output and input voltage curves

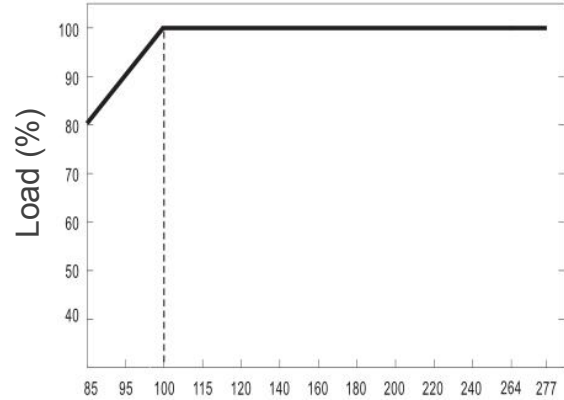

Input voltage(VAC)

Functional Diagram

